

## **Development and Validation of an Instrument for Measuring Technical Teachers' Attitudes towards Teaching Engineering Drawing**

**Hassan, B., Alias, M.\* and Awang, H.**

*Faculty of Technical and Vocational Education, Universiti Tun Hussein Onn Malaysia, 86400 Parit Raja, Batu Pahat, Johor, Malaysia*

### **ABSTRACT**

The ability to conduct valid assessment of teachers' attitude towards teaching of a technical course is important as teachers' attitude influences the quality of teaching and students' learning experience. This paper focuses on the development and validation of an instrument for assessing technical teachers' attitudes towards teaching engineering drawing. The study used a developmental research design method. Three factors of attitude were postulated and 19 items were constructed based on the understanding gained from existing literature. The draft instrument was piloted on a sample of 235 teachers and analysed using Principal Component Analysis (PCA) method, specifically Exploratory and second order Confirmatory Factor Analysis (EFA & CFA) techniques with orthogonal varimax rotation. The results indicate that all 19 items are properly loaded on the three postulated factors, providing evidence for the construct validity of the instrument. The overall reliability of the instrument based on inter-item consistency was found to be high ( $\alpha = 0.81$ ) and therefore, scores obtained using the instrument are reliable. In conclusion, the findings indicate that the instrument is a valid and reliable tool for measuring teachers' attitudes towards teaching engineering drawing.

*Keywords:* Attitude scale, engineering drawing, technical teachers

### **ARTICLE INFO**

*Article history:*

Received: 01 November 2016

Accepted: 15 April 2017

*E-mail addresses:*

19bashzali66@gmail.com (Hassan, B.),

maizam@uthm.edu.my (Alias, M.),

halizah@uthm.edu.my (Awang, H.)

\* Corresponding author

### **INTRODUCTION**

Teachers with their knowledge and skills are the most important human resources in schools to influence human resource development through students' performance (Ministry of Education Government of India, 1970). In particular, teachers' attitudes

play a crucial role towards achieving set educational goals (Pintrich & Schunk, 1996). Attitude, which reflects feeling and emotions, is an individual's prevailing predisposition towards responding favourably or unfavourably to an object or event (Morris, Charles, & Maisto, 2003). Attitudes can be positive, negative or neutral and also dormant and more generalised and are made up of three components namely, the affective, cognitive and behavioural components (Kreitner, Kinicki, & Cole, 2007).

Teachers' feeling and emotions influence their attitude towards teaching quality, which in turn influences students' satisfaction and learning performance. For example, Denessen, Vos, Hasselman and Louws (2015), and Frenzel, Goetz, Lüdtke, Pekrun and Sutton (2009) found that teachers' enjoyment in teaching was positively associated with students' learning satisfaction. The more teachers enjoyed their teaching, the more enthusiastically they taught and the more students enjoyed the lesson. Similar effects of teachers' attitude towards their teaching subject were observed by Mastin (1960), who found that teachers' attitudes towards a particular subject influenced students' attitudes towards that subject. In particular, students tended to have poorer attitudes when teachers lacked ability, confidence and enthusiasm (Mastin 1960 as cited in Denessen, Vos, Hasselman, & Louws, 2015). Thus, teachers with a positive attitude tend to affect students positively, while teachers with a negative attitude affect students negatively.

Quality management in the education system is designed to achieve set standards through proper planning, adequate supervision and timely evaluation and monitoring to ensure quality education delivery (Sahu, Shrivastava, & Shrivastava, 2013). Assessment of teachers' attitude through valid instrument, thus, can provide information on teachers' needs, which can then be addressed to improve performance in instructional delivery. Numerous studies on development and validation of attitude measures have been conducted (Kulinna, Cothran, & Regualos, 2003; Ezeudu, Chiahah, & Eze, 2013; Zahra & Bee, 2013; Anthonia, 2014), but most of these focused on students' attitudes towards learning, in particular learning of the sciences. There are currently limited studies on the development and validation of instruments for attitude measurement among teachers. Two notable studies on instrument development for measurement of teachers' attitudes deal with teaching the sciences (Tortop, 2013; Van Aalderen-Smeets, & Van der Molen, 2013). Tortop (2013) attempted to develop a Teacher's Attitude Scale towards Science Fair (TASSF), while Van Aalderen-Smeets and Van der Molen (2013) developed an instrument for assessing the attitude of in-service and pre-service primary-school teachers towards teaching the sciences, the Dimensions of Attitude towards Science (DAS) instrument. Both instrument development examples are for assessing the attitude of science teachers. No available study was found on the development of an attitude instrument for technical teachers,

in particular with regards to teaching engineering drawing courses. Demand for engineering drawing teachers is high and the teaching of engineering drawing is challenging as it requires a high level of spatial visualisation skills in addition to cognitive skills (Akasah & Alias, 2010). Thus, sometimes less competent teachers are hired to teach the course, which may negatively impact the quality of teaching especially if the teachers are also suffering from poor attitude towards teaching engineering drawing. Thus, knowing the attitudes of technical teachers towards teaching engineering drawing is important and having a valid measure of their attitude is essential if the assessment data are to be used in decision making. The aim of this study was to develop and validate an instrument to measure technical teachers' attitude towards teaching engineering drawing.

## METHODOLOGY

This study employed a developmental research design method. This type of design provides for production of knowledge with the goal of improving processes of instructional design, development and evaluation. Adamski (2000, p. 40) defined developmental research as "the systematic study of designing, developing and evaluating instructional programs processes, and products that must meet the criteria of internal consistency and effectiveness." While developmental research is only one of several types of research methods that can provide experts with usable data, its focus

on the design, development and evaluation of instructional products and processes is unique (Richey & Klein, 2005).

Developmental research can be described as Type I and Type II developmental research (Richey & Klein, 2004). Type I describes the development of the entire design based on extensive research grounded in a specific context. This category, according to Richey and Klein (2004), typically involves situations in which the product development process used in a particular situation is described and analysed, and the final product is evaluated. This type of developmental research includes "activities performed during the entire development process of a specific intervention from exploratory studies through (formative and summative) evaluation studies" (p. 1102). Type II developmental research is orientated toward a general analysis of design, development or evaluation process, addressed either as a whole or regarding a particular component. It is the overlaying of a tested design onto existing programmes to improve outcomes. Table 1 presents the types of and phases of developmental research. With regards to measurement scale development, the process usually involves four stages namely, defining constructs and determining domain content, generating items for the survey and judging the appropriateness of the items, designing and conducting studies to test the scale and lastly, finalising the scale based on data collected in the third stage (Burton & Mazerolle, 2011, p. 29).

Table 1  
*Developmental research types and common research methods employed for a particular study*

Type of Developmental Research	Functions/Phase	Research Methodology Employed
Type 1	Product Design and Development	Case Study, In-Depth Interview, Field Observation, Document Analysis
Type 1	Product Evaluation	Evaluation, Case Study, Survey, In-depth Interview Document Analysis
	Validation of Tool or Technique	Evaluation, Experimental, Expert Interview, In-depth Interview, Survey
Type 2	Model Development	Literature Review, Case Study, Survey, Delphi, Think-Aloud Protocols
Type 2	Model Use	Survey In-Depth Interview, Case Study, Field Observation, Document Analysis
Type 2	Model Validation	Experimental, In-Depth Interview, Expert Review, Replication

Source: Richey & Klein, (2005)

The Attitude Scale development process follows the steps outlined by Burton and Mazerolle (2011, p. 29), which will be explained next.

### **Stage 1: Defining Constructs and Determining Domain Content**

The constructs and domain content for the attitude scale were determined from knowledge gained from the existing literature. In this study, attitudes are the degree of belief adopted by teachers towards teaching Engineering Drawing. Teachers' attitudes towards their teaching of Engineering Drawing were developed based on the three components of attitudes (affective, cognitive and behaviour) identified through literature review of teachers' attitude towards teaching (Patrick, 2014; McLaren, 2007; Wagah, Indoshi,

& Agak, 2009; Fishbein & Ajzen, 1975). Thus, in this study, the measurement of technical teachers' attitude is composed of three latent constructs: the affective (feeling and emotions about the course), cognitive (knowledge and skills related to the course) and behaviour towards teaching the course.

### **Stage 2: Generating Items for the Survey and Judging the Appropriateness of the Items**

Items were generated to operationalise the concept of attitude towards teaching engineering drawing. The conscripting of those items emerged from the fieldwork of different technical education teachers who are experts in the subject matter. Thirty-six items were initially drafted and subjected for review by a panel of experts, after which 24 items were selected and clustered

into three factors: affective (feeling and emotions), cognitive (knowledge and skills) and behavioural. The details of the items conscriptions process is shown in Figure

1, which is consistent with the suggestions from Costa and Polak (2015), Schutt (2011) and Vaske (2008).

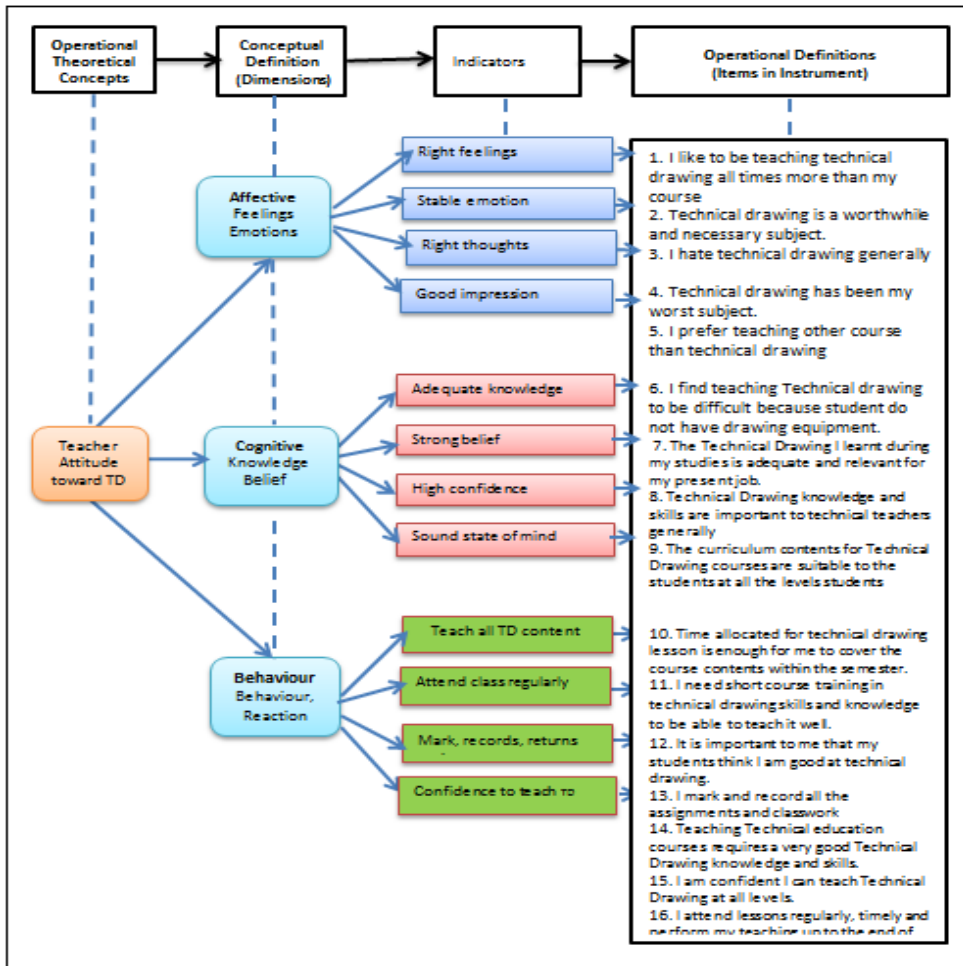

Figure 1. Generating items to operationalise the theoretical concept of attitude towards teaching engineering drawing

### Stage 3: Designing and Conducting Studies to Test the Scale

Two hundred and seventeen technical education teachers from the six institutions

offering NCE technical education programmes in Northern Nigeria (Table 2) participated in the testing of the instrument. These institutions were established

specifically to groom and produce teachers in technical, vocational and commercial as well as academic disciplines leading to the Nigeria Certificate in Education (NCE TECH). The aim of this study was to test the construct validity of the scale based on an existing theoretical framework; this is an important step when a new

instrument is being developed (Melorose, Perroy, & Careas, 2000). For this purpose, the respondents were asked to rate their agreement based on a 5-point Likert scale with 1='Strongly Disagree' and 5='Strongly Agree'. The sum of the relevant items in each subscale represented the strength of the respondent's attitude.

Table 2  
*Distribution of respondents according to institution*

S/N	Name of Institution	Respondents			
		Heads of Department (HoD)	Teachers'	Students'	Total
1	Federal Colleges of Education (Technical) Bichi	5	49	50	104
2	Federal Colleges of Education (Technical) Gombe	5	56	50	111
3	Federal Colleges of Education (Technical) Gusau	5	27	50	82
4	Federal Colleges of Education (Technical) Potiskum	5	59	50	114
5	College of Education Minna	5	19	50	74
6	Kaduna Polytechnic	5	25	50	80
Total		30	235	300	565

The results of the Exploratory Factor Analysis (EFA) are discussed in the next section.

**Stage 4: Finalising the Scale**

After pilot-testing the scale, it was finalised using further analysis. The results of the Confirmatory Factor Analysis (CFA) are presented in the next section.

**RESULTS AND DISCUSSION**

**Exploratory Factor Analysis (EFA)**

EFA was used to determine the underlying structure of the data. EFA is a multivariate statistical procedure commonly used in the social sciences, education and other related fields (Williams & Brown, 2012). It is an orderly simplification of interrelated measures applied to a single set of

variables and is used to explore the possible fundamental structure of a set of interrelated variables without imposing any defined structure on the outcome. This study of the development and validation of instruments for measuring teachers' attitude towards teaching engineering drawing was then undertaken to find the underlying structure of the data.

Factor analysis was carried out on 24 items for the primary components using orthogonal rotation (varimax) on the

assumption that the factors are uncorrelated with one another. Five items were deleted because their factor loadings were less than 0.4 or loading on more than one factor, leaving a total of 19 items. Table 2 below presents the loading pattern after the deletion with varimax rotation. The 'affective' factor was loaded with eight items, the 'cognitive' factor was loaded with six items and the 'behaviour' factor was loaded with five items.

Table 3  
*Factor structures and loadings of 19 items with a Varimax Rotation on the attitude towards Teaching Engineering Drawing Scale*

S/N	Items	Description	Factor Loadings	Factor Label	Cronbach's Alpha
1	AFF1	I would like to teach Engineering Drawing all the time, more than my course.	0.725	Affective	0.88
2	AFF2	I hate Engineering Drawing generally.	0.860		
3	AFF3	I prefer teaching courses other than Engineering Drawing.	0.791		
4	AFF4	I find teaching Engineering Drawing to be difficult because the students do not have drawing equipment.	0.762		
5	AFF5	It is important for me to be recognised by my students as a competent Engineering Drawing teacher.	0.576		
6	AFF6	Engineering Drawing is a worthwhile and necessary subject in technical education programmes.	0.706		
7	AFF7	Engineering Drawing has been my worst subject.	0.729		
8	AFF8	Most technical teachers hate to teach Engineering Drawing.	0.669		
9	COG1	The Engineering Drawing learnt during my studies is adequate and relevant to my present job.	0.888	Cognitive	0.77
10	COG2	Engineering Drawing knowledge and skills are important to technical teachers.	0.879		
11	COG3	The curriculum content for Engineering Drawing courses is suitable for the students at all levels.	0.817		

Table 3 (continue)

12	COG4	The time allocated for Engineering Drawing is enough for me to cover the course content within the semester.	0.674		
13	COG5	I need a short course on training in Engineering Drawing skills and knowledge to be able to teach it well.	0.831		
14	BEH1	Teaching Engineering Drawing is important for all technical education students' future career.	0.743		
15	BEH2	I mark and record all Engineering Drawing assignments and class work.	0.758	Behaviour	0.79
16	BEH3	I am confident and can teach Engineering Drawing content for all levels.	0.787		
17	BEH4	I attend my Engineering Drawing lessons regularly and on time and perform my teaching up to the end of the lesson.	0.681		
18	BEH5	I use different teaching methods to teach Engineering Drawing.	0.723		
19	BEH1	I teach Engineering Drawing because I am required to.	0.737		

The KMO measures for the second-order construct of attitude showed that the data were factorable as the Bartlett's test of sphericity was high (2357.995) and the Kaiser-Meyer-Olkin (KMO) criterion was 0.856, indicating that the data were adequate for the EFA (Shiyaku, Kasim, & Harir, 2016; Hair, Black, Babin, & Anderson, 2010; George, Leech, & Barrett, 2005). The communality tables for the construct showed a high relationship between the variables and all other items before rotation, as most communalities ranged from 0.410 to 0.807, which was very good, meaning that there was no small sample size in the factors that could distort the results (George, Leech, & Barrett, 2005).

The Eigen values obtained for each factor (affective, cognitive and behaviour) were greater than 1.0 (4.778, 4.304 and

3.162, respectively), explaining a total variation of 64.441% (25.15%, 22.65% and 16.64%, respectively). This takes us to the next level of validation of the instrument via Confirmatory Factor Analysis (CFA). However, before progressing to CFA, the estimates of reliability for the draft revised scale were obtained (see Table 3). The scale and subscales seemed to have adequate reliability based on the internal consistency coefficients.

Table 4  
Reliability results for HODs, teachers and students

Constructs	Number of Items	Teachers' Cronbrach's Alpha
Overall Attitude	19	0.81
Affective	8	0.88
Cognitive	6	0.77
Behaviour	5	0.79



**Confirmatory Factor Analysis (CFA)**

To finalise the scale, CFA was conducted. The objective of the CFA was to test how well the hypothesised model fit the observed data and minimised the difference between them (Yu & Strobel, 2013). As with the Exploratory Factor Analysis (EFA), CFA was performed on the attitude constructs using three-factor models, the three factors being the affective, cognitive and behaviour aspects. All the 19 observed variables of the three latent variables of attitude were initially incorporated, and the result did not show acceptable goodness of fit with the sample data based on the threshold

suggested (Hair, Black, Babin, & Anderson, 2010). All the fitness indices indicated good fit except for the NFI and the GFI, which are slightly less than the suggested 0.90 and above (Hair, Black, Babin, & Anderson, 2010; George, Leech, & Barrett, 2005). The RMSEA was 0.062, which is below the recommended index of less than 0.080, while the GFI was 0.888, CFI, 0.945, TLI, 0.938 and NFI, 0.888. Even though the ChiSq/df and RAMSEA indicated good fit at 1.824 and 0.062, respectively, according to the models and the modification indices, the initial model needed to be improved to fit the sample data better (Figure 2).

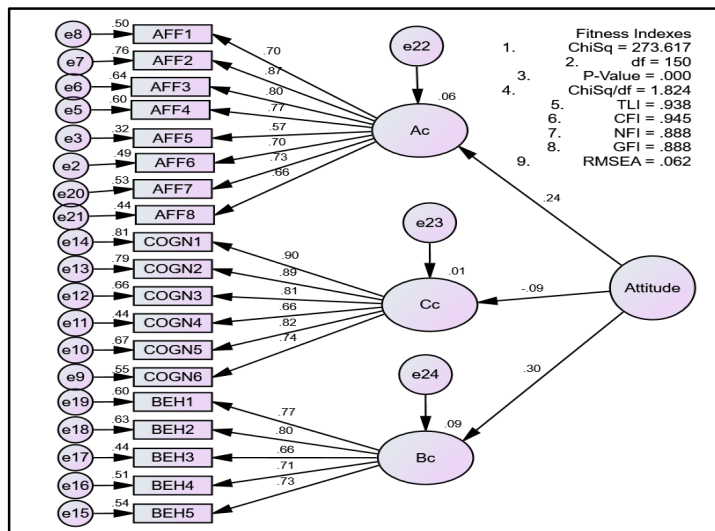

Figure 2. First iteration of the CFA for the attitude construct of the measurement model

Because of the weak index of the NFI (0.888) and the GFI (0.888), a second and final iteration became necessary. Two criteria were employed to identify the items with imperfect behaviour in the model. The details of the criteria are as follows:

the model's modification indices (MI) showed that if the analysis were repeated by treating the covariance between e2 and e21 as a free parameter, the model fit would increase. Removal of any observed variables identified with the least squared multiple

correlations may also have improved the model fitness. Based on these criteria, AFF5 was found to have the least squared multiple correlation of 0.57; as a result, it was considered for elimination.

The modification indices (MI) showed that if the analysis were repeated by treating the covariance between e2 and e21 as a free

parameter, the fitness of the model would be increased. After the removal of item AFF5 and covarying e2 and e21, a re-run analysis on the remaining items in the model gained significant goodness of fit with the sample data and retained the revised specification of the structural model (Figure 3).

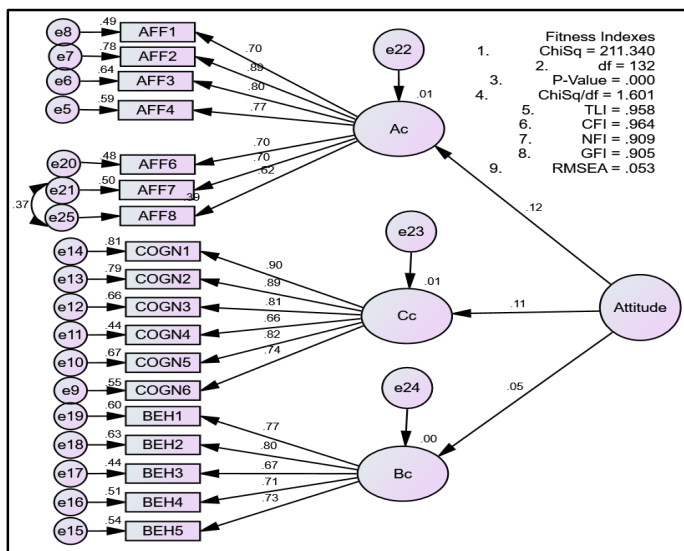

Figure 3. Second and final iteration of CFA for the attitude construct of the measurement model

Finally, only one item was removed from the model and this resulted in 18 items comprising the attitude construct. The final model's fit indices were: ChiSq/df = 1.601, TLI = 0.958, CFI = 0.964, NFI = 0.909, GFI = 0.905 and RAMSEA = 0.053. The adjusted model fits the sample data well (Figure 3).

## CONCLUSION

This study was conducted to develop and validate a reliable instrument for measuring teachers' attitude towards

engineering drawing and teaching of the subject. The principal component analysis method using Exploratory Factor Analysis (EFA) and Confirmatory Factor Analysis (CFA) techniques with orthogonal varimax rotation indicated that the domains of teachers' attitude towards engineering drawing evolved from feeling and emotions, knowledge and skills and behaviour related to the subject. The three factors namely, the affective, cognitive and behaviour factors, were the order of attitudes believed to be a

vital part of the measuring instrument and thus, were looked into in assessing technical teachers' attitudes towards teaching engineering drawing in technical education institutions running technical education programmes. The internal consistency coefficient for the overall scale and sub-scales were found to be adequate and thus, could produce reliable scores on attitudes. In conclusion, the data indicated that the instrument developed was valid and reliable for measuring technical teachers' attitude towards teaching engineering drawing.

## REFERENCES

- Adamski, A. J. (2000). The development of a job performance aid design model for use in aviation. *Journal of Aviation/Aerospace Education Research*, 10(1), 38–58.
- Akash, Z. A., & Alias, M. (2010). Bridging the spatial visualisation skills gap through engineering drawing using the whole-to-parts approach. *Australasian Journal of Engineering Education*, 81–6.
- Anthonia, N. (2014). Factorial validation of an instrument for the assessment of practical chemistry skills acquisition. *J. Educ. Pract.*, 5(8), 175–185.
- Burton, L. J., & Mazerolle, S. M. (2011). Survey instrument validity, part 1: Principles of survey instrument development and validation in athletic training education research. *Athl. Train. Educ. J.*, 6(1), 27–35.
- Costa, A. L. S., & Polak, C. (2009). Construction and validation of an instrument for the assessment of stress among nursing students. *Rev. Esc. Enferm. USP*, 43(Spe), 1017–26. Retrieved from www.ee.usp.br/reecusp
- Denessen, E., Vos, N., Hasselman, F., & Louws, M. (2015). The relationship between primary school teacher and student attitudes towards science and technology. *Educ. Res. Int.*, 2015, 1–7.
- Ezeudu, F. O., Chiaha, G. T. U., & Eze, J. U. (2013). Development and validation of teaching practice evaluation instrument for assessing chemistry students' teaching skills. *US-China Educ. Rev.*, 3(2), 83–91.
- Fishbein, M., & Ajzen, I. (1975). *Belief, attitudes, intention and behaviour: An introduction to the theory of reasoned action*. Reading, MA: Addison-Wesley.
- Frenzel, A. C., Goetz, T., Lüdtke, O., Pekrun, R., & Sutton, R. E. (2009). Emotional transmission in the classroom: Exploring the relationship between teacher and student enjoyment. *J. Educ. Psychol.*, 101(3), 705–716.
- Kreitner, R., Kinicki, A., & Cole, N. (2007). *Fundamentals of organizational behaviour key concepts, skills, and best practices*. Toronto: McGraw-Hill Ryerson, p. 360.
- Kulinna, P. H., Cothran, D., & Regualos, R. (2003). Development of an instrument to measure student disruptive behavior. *Meas. Phys. Educ. Exerc. Sci.*, 7(1), 25–41.
- McLaren, S. V. (2007). Exploring perceptions and attitudes towards teaching and learning manual technical drawing in a digital age. *Int. J. Technol. Des. Educ.*, 18(2), 167–188.
- Melrose, J., Perroy, R., & Careas, S. (2000). Raising research awareness among midwives and nurses: Does it work? *J. Adv. Nurs.*, 31(1), 78–88.
- Ministry of Education Government of India. (1970). *Report of the education commission 1964-66*. New Delhi: Government of India Press.
- Morris, C. G., & Maisto, A. A. (2003). *Understanding psychology* (6<sup>th</sup> ed.). New Jersey: Prentice Hall.

- Patrick, A. (2014). Attitude influence on performance in technical skill acquisition among formal technical trainees. *International Journal of Research Studies in Education*, 3(5), 103–112.
- Richey R., & Klein, J. D. (2005). Developmental research methods: Creating knowledge from instructional design and development practice. *J. Comput. High. Educ.*, 16(2), 23–38.
- Richey, R. C., Klein, J. D., & Nelson, W. A. (2004). Developmental research: Studies of instructional design and development. *Handbook of research for educational communications and technology*, 2, 1099-1130.
- Sahu, A. R., Shrivastava, R. R., & Shrivastava, R. L. (2013). Development and validation of an instrument for measuring critical success factors (CSFs) of technical education – A TQM approach. *Int. J. Product. Qual. Manag.*, 11(1), 29.
- Schutt, R. K. (2011). *Investigating the social world: The process and practice of research 7*. Massachusetts: Sage Publication.
- Tortop, H. (2013). Development of teachers' attitude scale towards science fair. *Educ. Res. Rev.*, 8(2), 58–62, 2013.
- Van Aalderen-Smeets, S., & Van der Molen, J. W. (2013). Measuring primary teachers' attitudes toward teaching science: Development of the dimensions of attitude toward science (DAS). *Frontline Learning Research*, 2(2013), 1–11.
- Vaske, J. (2008). Conceptualization and measurement. *Surv. Res. Anal. Appl. Park. Recreat. Hum. Dimens.*, 59–77.
- Wagah, M. O., Indoshi, F. C., & Agak, J. O. (2009). Attitudes of teachers and students towards art and design curriculum: Implications for vocational education in Kenya. *Educational Research and Reviews*, 4(10), 448–456.
- Zahra S., & Bee H. T. (2012). Developing a questionnaire to measure students' attitudes toward the course blog? *Turkish Online J. Distance Educ.*, 12(1), 200–211.