



Passive Damping Techniques with LCL Filter in Inverter-Grid Connected

Erum Pathan* and Shamsul Aizam Zulkifli*

Faculty of Electrical and Electronic Engineering, Universiti Tun Hussein Onn Malaysia, 86400 Parit Raja, Batu Pahat, Johor, Malaysia

ABSTRACT

In this paper, the challenge of harmonic injection mitigation becomes critical with the massive use of inverters in electrical distribution systems that has been discussed and analyzed. Currently, between the inverter and the grid, L, LC or LCL filters is often used to mitigate the current harmonic. Further, filter connection in both delta-to-star or star-to-delta transformer for state space model of LC filter couplings with impedance is obtained in this paper and it also talked about the different passive damping techniques that been used to suppress the resonance effect on the filter. The effect of series and parallel damping resistor techniques that impact filtering and stability are also been analyzed and discussed. At the end, the simulation results show that LCL filter with parallel damping resistor achieves best performance compared on those for L, LC, or LCL with series damping resistor while at the same time enhancing the smoothness of the signal output while at the same time reducing the percentage of total harmonic distortion between inverter-grid connection.

Keywords: Series Damping Resistor (SDR), Parallel Damping Resistor (PDR), Voltage Source Inverter (VSI)

INTRODUCTION

The voltage source converters (VSCs) have become an essential part of many prime

movers and appliances when connecting to the grid (Liu et al, 2009). Traditionally VSCs are connected with an inductor L, in order to reduce the switching frequency ripple current, although many topologies can be found in the literature incorporating only L-type filter (Akagi, 1996; Bolsens et al., 2006; Teodorescu et al, 2004). However, it is well-known that such an output filter may not be sufficient to meet power quality standards given in IEEE 519 or IEC 61000-3-2 (Twining

ARTICLE INFO

Article history:

Received: 24 August 2016

Accepted: 03 Jun 2017

E-mail addresses:

erumasad79@gmail.com (Erum Pathan),

aizam@uthm.edu.my;

s.aizam@yahoo.com.my (Shamsul Aizam Zulkifli)

*Corresponding Author

et al., 2003), because of the existing high-current ripple due to the Pulse Width Modulation (PWM) of the inverter. To further reduce the effect of thus PWM harmonics, more complex output filter can be used, such as an inductance capacitance (LC) or inductance capacitance inductance (LCL) topologies suggested in (Shen et al., 2008; Shanxu et al., 2010; Wang et al., 2003). Although, LCL filter may reduce costs and improve dynamic response, but a small inductor value is necessary to achieve the required performance in reducing the switching harmonics in comparison with L or LC filter. Particularly, in large power system where the frequency is low, whereby the advantages of LCL filter are more evident.

As known, LCL filter needs smaller inductance value compared to L-type filter for the same performance in harmonic suppression, where it is used in high-power and low-frequency current source controlled in grid-connected converters (Wu et al., 2013 a; Pena-Alzola et al., 2013a). However, LCL filter parameters design is not only related to the switching frequency or ripple attenuation but also related to the performance of the grid-current control loop (Kroutikova et al., 2007). In (Liserre et al., 2005; Julean et al., 2009) a detailed design procedure of an LCL filter was presented. According to the requirements of current ripple tolerance, voltage drop, resonance frequency, reactive power rate, and losses are needed to be considered before the LCL filter parameters can be designed.

In (Renzhong et al., 2013) the L, LC, and LCL filters have been compared and showed that the LCL filter give an excellent harmonic suppression capability, while at the mean time the LCL filter generates a significant resonance peaks that effect the system stability. Therefore, a damping technique must be introduced in order to improve the peak of the system. There are many passive and active methods are been proposed in order to satisfy the system stability requirements. In order to suppress LCL filters resonance, passive methods (Wu et al., 2013) are easier and cheaper to implement. The basic types of passive damping methods are described in (Wu et al., 2013c; Julean, 2009b) where Passive elements like resistor, inductor and capacitor are placed by using different combinations. However, it is really ambitious to trade-off losses and filter performance.

This paper presents a state-space model of LC filter coupling with impedances in star and delta connected capacitors will be discussed in Section 2. Then the effective passive damping methods will be presented in Section 3. At the end, the simulation result will prove that the LCL filter achieves the best performance, indicated the impacts on the stability and filtering property from the parallel resistor or series resistor will discuss in Section 4. Finally, this paper will be concluded in Section 5.

STATE-SPACE MODELS OF LC FILTER AND COUPLING IMPEDANCE IN STAR AND DELTA CONNECTED CAPACITORS

The LC filter and coupling impedance with Y and Δ connected capacitors are illustrated in Figure 1(a, b), where L_i is the inverter-side inductor L_c is the coupling grid-side inductor, C_f is a capacitor with a series R_f damping resistor, R_i and R_c are inductors resistances, V_{in} is an inverter output and V_{eg} as system output or grid side voltage. Other then that, I_{ia} , I_{ib} , I_{ic} , V_{ia} , V_{ib} , V_{ic} are per phase voltage and current of inverter side inductance whereas, I_{ga} , I_{gb} , I_{gc} , V_{ga} , V_{gb} , V_{gc} are per phase system output side voltage and current.

The selection of the inductor and capacitor involve some design consideration due to the dynamic effect that needs to be consider for low-frequency harmonics and the effect of the inductance if a transformer is been used to connect the inverter with the grid as shown in Figure 1 .How to design the output filter circuit is out of the scope of this paper but the reader can find the detailed of this filter in (Julean, 2009c).

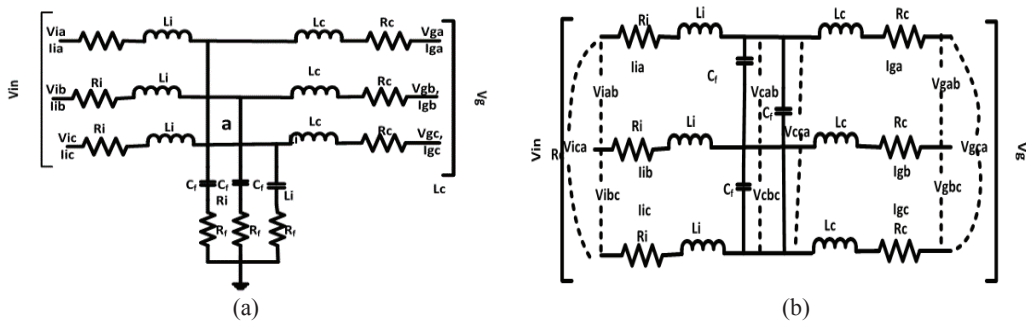

Figure 1(a, b). LC Filter and Coupling Impedance star and delta connected capacitors

The equations describing the phase a, b and c of the filter in star and delta connected is tabulated in Table 1.

Table 1
Star and delta connected parameters equations

| Star connected capacitor equations | Delta connected equations |
|---|---|
| $\frac{dv_{c\phi}}{dt} = \frac{1}{C_{f\phi}} i_{i\phi} - \frac{1}{C_{f\phi}} i_{g\phi}$ | $v_{ca} + v_{cb} + v_{cc} = 0, \frac{dv_{c\phi}}{dt} = \frac{1}{3C_f} i_{i\phi ab} - \frac{1}{3C_f} i_{g\phi ab}$ |
| $\frac{di_{i\phi}}{dt} = \frac{1}{L_{i\phi}} v_{i\phi} - \frac{R_{1\phi} + R_{f\phi}}{L_{i\phi}} i_{i\phi} - \frac{v_{c\phi}}{L_{i\phi}} + \frac{R_{f\phi}}{L_{i\phi}} i_{g\phi}$ | $\frac{dv_{c\phi a}}{dt} = \frac{1}{3C_{f\phi}} i_{i\phi ab} - \frac{1}{3C_{f\phi}} i_{g\phi ab}$ |
| $\frac{di_{g\phi}}{dt} = \frac{1}{L_{c\phi}} v_{c\phi} + \frac{R_{f\phi}}{L_{c\phi}} i_{i\phi} - \frac{R_{c\phi} + R_{f\phi}}{L_{c\phi}} i_{g\phi} - \frac{V_{g\phi}}{L_{c\phi}}$ | $\frac{di_{i\phi ab}}{dt} = \frac{1}{L_{1\phi}} v_{i\phi ab} - \frac{R_{1\phi} + R_{f\phi}}{L_{1\phi}} i_{i\phi ab} - \frac{v_{c\phi}}{L_{1\phi}} + \frac{R_{f\phi}}{L_{1\phi}} i_{g\phi ab}$ |
| <p>here , $\phi = a , b , c$ (three phase system)</p> | $\frac{di_{g\phi ab}}{dt} = \frac{1}{L_{c\phi}} v_{i\phi c\phi} + \frac{R_{f\phi}}{L_{c\phi}} i_{i\phi ab} - \frac{R_{c\phi} + R_{f\phi}}{L_{c\phi}} i_{g\phi ab} - \frac{V_{g\phi ab}}{L_{c\phi}}$ |

In delta connected equations, $i_{i\phi ab} = i_{i\phi a} - i_{i\phi b}$, $i_{g\phi ab} = i_{g\phi a} - i_{g\phi b}$ where $\phi =$ phases A, B and C, with the general state space equation is given as follows:

$$\dot{x} = Ax + Bu \tag{1}$$

Whereas the state space representation of the equations for star and delta connected system are given in equation (2) and (3) respectively:

$$\begin{bmatrix} V_{c\phi} \\ i_{i\phi} \\ i_{g\phi} \end{bmatrix}_{9 \times 1} = \begin{bmatrix} I[0]_{3 \times 3} & I\left[\frac{1}{C_{f\phi}}\right]_{3 \times 3} & I\left[-\frac{1}{C_{f\phi}}\right]_{3 \times 3} \\ I\left[-\frac{1}{L_{1\phi}}\right]_{3 \times 3} & I\left[\frac{R_{1\phi}+R_{f\phi}}{L_{1\phi}}\right]_{3 \times 3} & I\left[\frac{R_{f\phi}}{L_{1\phi}}\right]_{3 \times 3} \\ I\left[\frac{1}{L_{c\phi}}\right]_{3 \times 3} & I\left[\frac{R_{f\phi}}{L_{c\phi}}\right]_{3 \times 3} & I\left[-\frac{R_{c\phi}+R_{f\phi}}{L_{c\phi}}\right]_{3 \times 3} \end{bmatrix}_{3 \times 3 \times 9 \times 9} \begin{bmatrix} V_{c\phi} \\ i_{i\phi} \\ i_{g\phi} \end{bmatrix}_{9 \times 1} + \begin{bmatrix} I\left[\frac{1}{L_{1\phi}}\right]_{3 \times 3} & I[0]_{3 \times 3} \\ I[0]_{3 \times 3} & I\left[-\frac{1}{L_{c\phi}}\right]_{3 \times 3} \end{bmatrix}_{6 \times 6} \begin{bmatrix} I[V_{iA}]_{3 \times 3} \\ I[V_{gA}]_{3 \times 3} \end{bmatrix}_{6 \times 1} \quad (2)$$

$$\begin{bmatrix} V_{c\phi} \\ i_{i\phi ab} \\ i_{g\phi ab} \end{bmatrix}_{9 \times 1} = \begin{bmatrix} I[0]_{3 \times 3} & I\left[\frac{1}{3C_{f\phi}}\right]_{3 \times 3} & I\left[-\frac{1}{3C_{f\phi}}\right]_{3 \times 3} \\ I\left[\frac{1}{L_{1\phi}}\right]_{3 \times 3} & I\left[-\frac{R_{1\phi}+R_{f\phi}}{L_{1\phi}}\right]_{3 \times 3} & I\left[\frac{R_{f\phi}}{L_{1\phi}}\right]_{3 \times 3} \\ I\left[\frac{1}{L_{c\phi}}\right]_{3 \times 3} & I\left[\frac{R_{f\phi}}{L_{c\phi}}\right]_{3 \times 3} & I\left[-\frac{R_{c\phi}+R_{f\phi}}{L_{c\phi}}\right]_{3 \times 3} \end{bmatrix}_{3 \times 3 \times 9 \times 9} \begin{bmatrix} V_{c\phi} \\ i_{i\phi ab} \\ i_{g\phi ab} \end{bmatrix}_{9 \times 1} + \begin{bmatrix} I\left[\frac{1}{L_{1\phi}}\right]_{3 \times 3} & I[0]_{3 \times 3} \\ I[0]_{3 \times 3} & I\left[-\frac{1}{L_{c\phi}}\right]_{3 \times 3} \end{bmatrix}_{6 \times 6} \begin{bmatrix} V_{i\phi ab} \\ V_{g\phi ab} \end{bmatrix}_{6 \times 1} \quad (3)$$

PASSIVE DAMPING METHODS

In LCL filter, the resonance effect can produce instabilities at the inverter output especially if some harmonic voltage/current is closed to resonant frequency (Pena-Alzola et al., 2013 b). To attenuate the possible resonances caused by the high-order power filter, whether at LC or at LCL filter, it is where an additional element which is a passive damping or active damping schemes should be adopted (Wu et al., 2013 d). In view of the suppleness and the cost, it mainly deals with LCL filter hardware circuit itself, so that sometimes the passive damping method is more attractive than the active damping. Notice that, bandwidth is always limited so that for certain frequencies active damping may not be able to actuate. Nevertheless, it is a challenge to balance the power losses or to have the satisfactory damping effect and to have the harmonic attenuation when selecting the damping parameters for a high order power filter (Wu et al., 2013 e). Passive damping is achieved by adding a resistance in series or in parallel with the capacitance as presented in next subsections.

R_d-series and parallel Damped LCL filter

The aim of using damping is to reduce the Q-factor at the characteristic resonance frequency. It is often easy to achieve by inserting a resistor in parallel or series with the capacitor as illustrated in Figure 2(a) and (b) respectively.

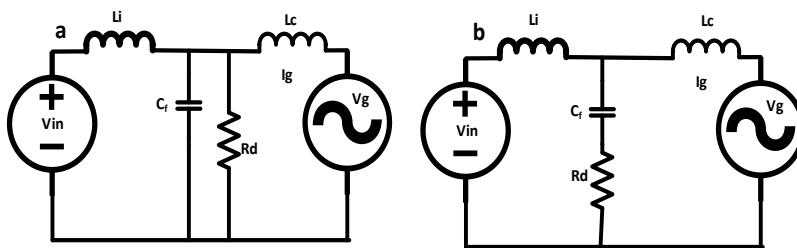

Figure 2. (a) damping R_d in parallel with C_f ; (b) damping R_d in series with C_f

The R_d -damped LCL filter is been inserted to avoid the resonance phenomenon. The equation for resonant frequency is given in equation (4)

$$f_r = \frac{1}{2\pi} \sqrt{\frac{L_i + L_c}{L_i L_c C_f}} \quad (4)$$

where f_r is resonant frequency, L_i is the inverter-side inductor, L_c is the coupling grid-side inductor, R_d is a damping resistor. It can be seen that, the R_d parameters is not consider in the Equation 4, where it does not affect the resonance of f_r (Wu et al., 2013 f).

The LCL filter transfer functions at line side current and inverter input voltage in a grid-connected mode of operation with series and parallel damping resistance are given in Equations 5 and 6 respectively. From the transfer functions, by analyzing those equations, larger series resistance values can give better damping or lower Q-factor, as can be seen from the transfer functions after damping are;

$$\frac{i_g}{V_{in}} = \frac{R_d C_f S + 1}{S^3 L_i L_c C_f + R_d C_f (L_i + L_c) S^2 + (L_i + L_c) S} \quad (5)$$

$$\frac{i_g}{V_{in}} = \frac{R_d}{S^3 L_i L_c C_f R_d + L_i L_c S^2 + (L_i + L_c) R_d S} \quad (6)$$

where the Q factor is proportional to R_d . If the selection of R_d is too big, the attenuation will be reduced which caused a harmonics problem to the LCL filter. However a higher R_d value can increase the losses at low frequency. In this case, as a hypothesis, this method cannot be used for higher power rating in the level of hundreds of kW or MW. For good filtering purposes, both parallel and series damping are suitable to be applied, but the question is to find out which one is better. The parallel and series resistor are described in Equation (7).

$$X_{series} = R_d + \frac{1}{C_f S} \quad , \quad X_{parallel} = \frac{R_d}{C_f R_d S + 1} \quad (7)$$

Due to the fact that the value of the series resistor is larger than the parallel resistor, the current that flows in series contain high-frequency harmonic current flow through capacitance compared in the parallel one. Therefore, the filter has a better effect of suppressing the high-frequency components. The spectrum characteristics are shown in Figure 3 (a, b) and the above approach was further proved and verified in simulation environment using MATLAB software.

SIMULATION RESULTS

Matlab/Simulink power system toolbox software was used to simulate the proposed approach. The designed LCL filter of the grid-connected inverter was simulated. and the calculated parameters is shown in Table 2.

In this paper, the simulation for LCL filter with series and parallel damping resistance are compared with the effect of both damping techniques. The presented simulation results are obtained for the harmonic current, voltage waveform for with and without damping techniques, as illustrated in following figures.

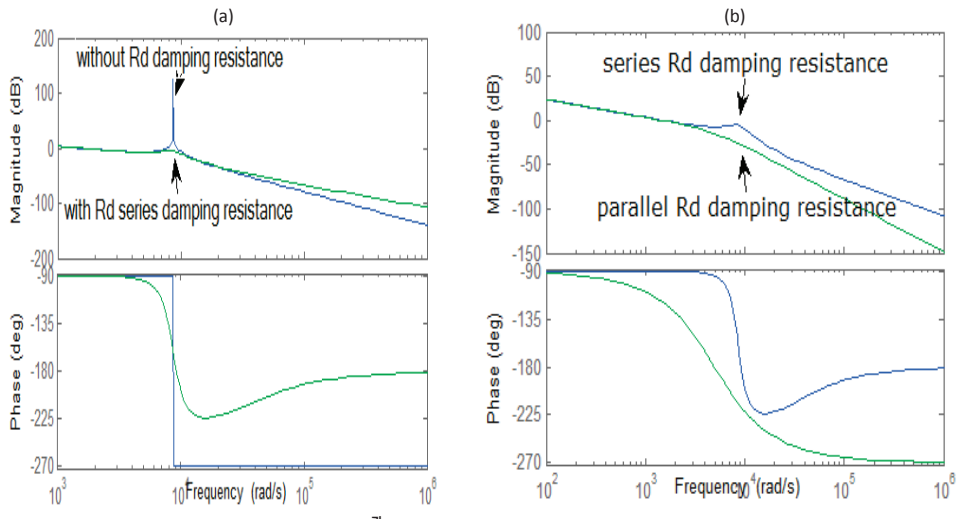

Figure 3. (a): Frequency response of $\frac{i_g}{V_{in}}$ with and without series R_d ; (b) series and parallel damping

Table 2
System parameters

| Parameters | Value |
|-----------------------------|-----------|
| V (Voltage) | 240/415 V |
| f (Frequency) | 50 Hz |
| P (Rated power) | 1 kW |
| F_s (Switching frequency) | 3 kHz |
| L_1 | 530 uH |
| L_2 | 143 uH |
| C_f | 118 uF |
| R_d | 0.3 ohm |

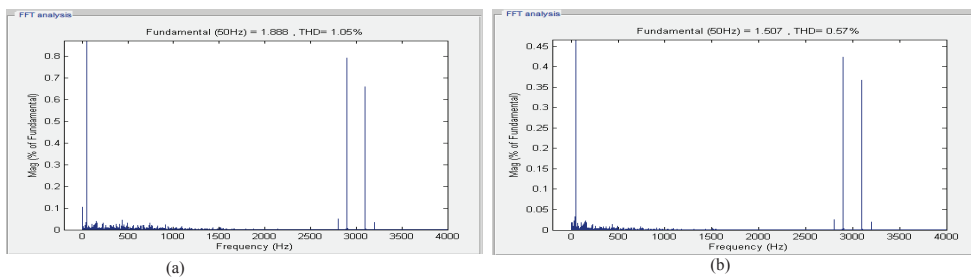

Figure 4. (a ,b): Harmonic waveform of LCL filter by (a) series damping (b) parallel damping resistance

Figure 4 (a) shows the THD is about 1.05% when series damping resistance is connected with LCL filter whereas in Figure 4. (b) is illustrated that THD of 0.57% is observed when damping resistance is connected in parallel with LCL filter. It is proved that, the parallel

resistance is the most effected arrangement at the inverter-grid connection where the R_d will help to increase the time constant of the filter.

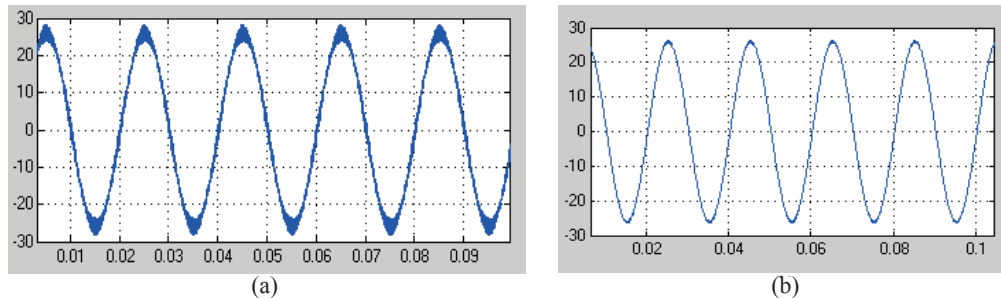

Figure 5. Current waveform (a) LCL filtering (b) with R_d +LCL filtering

The current output waveform without damping resistance gives high THD due to non quality signal that is effected on the inductor-capacitor respond which is illustrated in Figure 5(a). However, current waveform after filtering by LCL filter with the combination of the R_d has improve the quality of the signal as shown in Figure 5(b). This quality signal is necessary for the DSP process whereby it can affect the bit signal generated on the analog digital converter sensor in order to have a efficient power transfer between the inverter to the grid that will be discussed in next paper.

CONCLUSION

As a conclusion, this paper has investigated series and parallel resistive passive damping techniques in LCL filter for inverter-grid connection for star-delta and delta-star connection. The different damping methods are evaluated by showing the improve THD percentage with small bandgap of the bode plots between with or without damping resistor. As shows, the parallel resistance gives significant improvement to the quality of the signal. All features indicated that a better design can be obtained by using parallel connected damping techniques in LCL filter rather than series connection, especially for small and medium voltage source inverters connected to the grid.

ACKNOWLEDGEMENT

Authors gratefully acknowledge the support of Universiti Tun Hussein Onn Malaysia (UTHM) RAGS (R037) and Power and Renewable Energy Team (PaREnT), FKEE, UTHM to undertake this research activity.

REFERENCES

Akagi, H. (1996). New trends in active filters for power conditioning. *IEEE transactions on Industry applications*, 32(6), 1312-1322.

- Bolsens, B., De Brabandere, K., Van den Keybus, J., Driesen, J., & Belmans, R. (2004, June). Model-based Generation of low distortion currents in grid-coupled PWM-inverters using an LCL output filter. In *IEEE 35th Annual Power Electronics Specialists Conference, 2004. PESC 04. 2004* (Vol. 6, pp. 4616-4622). IEEE.
- Dahono, P. A. (2002). A control method to damp oscillation in the input LC filter. In *Power Electronics Specialists Conference, 2002. Pesc 02. 2002 IEEE 33rd Annual* (Vol. 4, pp. 1630-1635). IEEE.
- Julean, A. (2009). *Active damping of LCL filter resonance in grid connected Applications*. Aalborg Universitet Dinamarca, Dissertação de mestrado.
- Kroutikova, N., & Green, T. C. (2007). State-space model of grid-connected inverters under Current control Mode. *IET Electric Power Applications, 1*(3), 329-338.
- Liserre, M., Blaabjerg, F., & Hansen, S. (2005). Design and control of an LCL-filter-based Three-phase active Rectifier. *IEEE Transactions on Industry Applications, 41*(5), 1281-1291.
- Liu, F., Zha, X., Zhou, Y., & Duan, S. (2009, May). Design and research on parameter of LCL Filter in three-phase Grid-connected inverter. In *Power Electronics and Motion Control Conference, 2009. IPEMC'09. IEEE 6th International* (pp. 2174-2177). IEEE.
- Pena-Alzola, R., Liserre, M., Blaabjerg, F., Sebastián, R., Dannehl, J., & Fuchs, F. W. (2013). Analysis of the Passive damping losses in LCL-filter-based grid converters. *IEEE Transactions on Power Electronics, 28*(6), 2642-2646.
- Renzhong, X., Lie, X., Junjun, Z., & Jie, D. (2013). Design and research on the LCL filter in three-phase PV grid- Connected inverters. *International Journal of Computer and Electrical Engineering, 5*(3), 322.
- Rockhill, A. A., Liserre, M., Teodorescu, R., & Rodriguez, P. (2011). Grid-filter design for a Multimegawatt Medium- voltage voltage-source inverter. *IEEE Transactions on Industrial Electronics, 58*(4), 1205-1217.
- Shanxu, L. F. Z. X. D. (2010). Design and Research on Parameter of LCL Filter in Three-Phase Grid-Connected Inverter [J]. *Transactions of China Electro technical Society, 3*, 020.
- Shen, G., Xu, D., Cao, L., & Zhu, X. (2008). An improved control strategy for grid-connected Voltage source Inverters with an LCL filter. *IEEE Transactions on Power Electronics, 23*(4), 1899-1906.
- Teodorescu, R., Blaabjerg, F., Borup, U., & Liserre, M. (2004). A new control structure for grid -Connected LCL PV Inverters with zero steady-state error and selective harmonic compensation. In *Applied Power Electronics Conference and Exposition, 2004. APEC'04* (Vol. 1, pp. 580-586).
- Twining, E., & Holmes, D. G. (2003). Grid current regulation of a three-phase voltage source Inverter with an LCL Input filter. *IEEE Transactions on Power Electronics, 18*(3), 888-895.
- Wang, T. C., Ye, Z., Sinha, G., & Yuan, X. (2003, June). Output filter design for a grid - Interconnected three-phase inverter. *IEEE 34th Annual In Power Electronics Specialist Conference* (Vol. 2, pp.779-784). IEEE.
- Wu, W., He, Y., Tang, T., & Blaabjerg, F. (2013). A new design method for the passive damped LCL and LLCL filter-based single-phase grid-tied inverter. *IEEE Transactions on Industrial Electronics, 60*(10), 4339-4350.